

Concealed Tank and Carrier System with Dual-Flush Technology for Wall-Hung Toilets (UP300)



Model 111.335.00.1

Product Specifications

Concealed tank and carrier system with actuator flush panel for residential washdown wall-hung toilets. System shall fit within 5 1/2" (146 mm) framing wall or plumbing chase. Framing members should provide support similar to 2" x 6" (51 mm x 152 mm) wood construction or steel framing members placed 19 3/4" (500 mm) apart. Water supply shall have flow diameter no smaller than 1/2" (13 mm) copper tube, and a minimum flow pressure of 35 PSI (0.24 MPa). The toilet bowl shall be a third party listed low-consumption [1.6 GPF (6 LPF)], or High-Efficiency Toilet (HET) [1.28 GPF (4.8 LPF) single-flush] or

0.8 GPF (3 LPF) / 1.6 GPF (6 LPF) dual-flush] 2-hole wall-hung type. The carrier frame shall be adjustable for bowl rim heights from 15" (381 mm) to 19" (483 mm). Actuator flush panels shall be die-cast zinc, molded plastic or fabricated stainless steel and plated to preserve material integrity. All components shall be compliant with applicable codes and product standards.

Warranty

Limited lifetime warranty on tank and carrier, 10-year warranty on fill valve and flush valve. One-year warranty on actuator flush panels.

Features

- Water consumption – Dual-flush system allows for 0.8 GPF (3 LPF) or 1.6 GPF (6 LPF) giving effective flush volume of 1.1 GPF (4 LPF)
- Anti-siphon fill valve
- Impact resistant high density polyethylene (HDPE) tank
- Insulated to prevent condensation
- 16-gauge, powder-coated, structural-steel tubing rated to 880 lbs. (400 kg) without damage to finished wall or carrier unit
- Bowl rim height adjustments from 15" (381 mm) to 19" (483 mm)
- 47" (1200 mm) frame height
- Medium inspection opening

Complies with the latest editions of:

- ASME: A112.19.14, A112.19.2, A112.19.5, A112.6.2
- CSA B125.3
- ANSI/ASSE 1002
- UNAR / UNAR-HET
- WaterSense® compliant when matched to WaterSense approved bowl

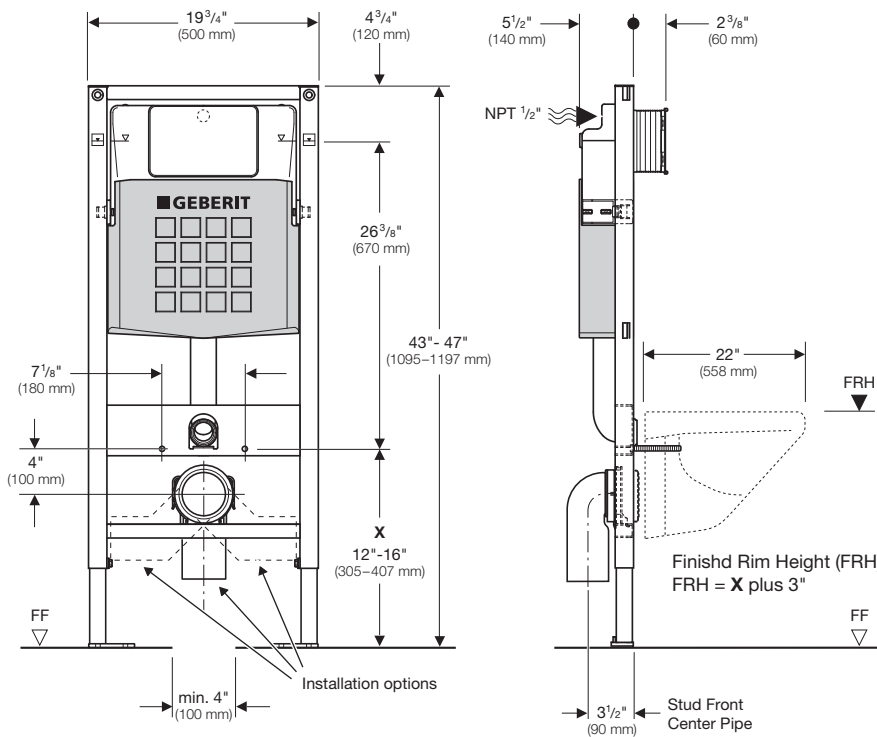

Product specifications subject to change without notice.

ARCHITECT/ENGINEER APPROVAL	
Job Name	_____
Date	_____
Quantity	_____
Model Specified	_____
Variations Specified	_____
Customer/Wholesaler	_____
Contractor	_____
Architect	_____

Geberit
2100 S. Clearwater Drive
Des Plaines, IL 60018

800/566-2100
Fax 847/803-5454
www.geberit.us